

TeleLite™

Power/Access Card (721123) Description and Installation Guide

925W720111-02E



Contents

Chapter 1 – General Information

1.1 Publication Information	6
1.2 About this Guide	7
Related Documentation.....	7
Positron Products and Services	7
1.3 Service and Support	8
Technical Customer Support.....	8
Customer Training.....	8
Repair Service.....	9
1.4 TeleLite Warranty	10
Limitation of Liability	10
Cancellation and Rescheduling Charges	11

Chapter 2 – Overview

2.1 TeleLite System Introduction	14
Introduction to the Power/Access Card model 721123.....	14
Power Contacts.....	14
Power Alarm 1 & 2 Contacts.....	15
Local Alarm 1 & 2 Contacts.....	15
Remote Alarm 1 & 2 Contacts.....	15
LED Indicators.....	15
Power/Access Card Specifications	18

Chapter 3 – Installation

3.1 Installing a Power/Access Card in a Shelf	20
---	----

Earthing Connector 22
Troubleshooting. 22

Appendix A – Acronyms

A 1 Acronyms 24

Chapter 1

General Information

1.1 Publication Information

© 2013 Positron Inc.

TeleLite Power/Access Card (721123)

Description and Installation Guide

Part number: 925W720111-02E

Publication date: September 27, 2013

Published By

Positron Inc.

5101 Buchan Street

Montreal, Québec, Canada

H4P 2R9

US and Canada: 1-888-577-5254

International: 1-514-345-2220

Trademarks

TeleLite is a trademark of Positron Inc.

Product names, other than Positron's, mentioned herein may be trademarks and/or registered trademarks of their respective companies

Confidentiality Notice

The information contained in this document is the property of Positron Inc. Except as specifically authorized in writing by Positron Inc., the holder of this document: 1) shall keep all information contained herein confidential and shall protect same in whole or in part from the disclosure and dissemination to all third parties, and 2) shall use same for operating and maintenance purposes only.

Disclaimer Notice

Although Positron Inc. has made every effort to ensure the accuracy of the information contained herein, this document is subject to change without notice.

1.2 About this Guide

This guide introduces you to the TeleLite Power/Access Card (721123), its features and applications, and describes how to install it in a TeleLite shelf. This guide was designed to be read from beginning to end.

1.2.1 Related Documentation

To order any manuals, please contact your customer service representative. Information is also available on our website: www.PositronPower.com.

1.2.2 Positron Products and Services

Positron engineers and manufactures high voltage isolation products to protect personnel and telecommunications circuits in high voltage areas that are susceptible to the effects of Ground Potential Rise (GPR).

Positron is the leader in isolation technology with its Teleline wireline products and TeleLite optical fiber wireline isolation/protection product families. Positron provides total flexibility in product configuration – from standalone units protecting a single circuit to high-capacity, multi-shelf HVI preconfigured systems.

Positron also provides a wide range of consulting, analysis and training services for communications companies and electrical utilities.

Full details and contact information are available at www.PositronPower.com.

1.3 Service and Support

Table 1: Positron Contact Information

General information:	Positron Inc. 5101 Buchan Street, Suite 220 Montreal, Quebec, Canada H4P 2R9 US and Canada: 1-888-577-5254 International: 1-514-345-2220 Fax: 514-345-2271 E-mail: info@positronpower.com Website: www.positronpower.com
Customer Service and Repairs:	US and Canada: 1-888-577-5254 International: 1-514-345-2220 E-mail: customerservice@positronpower.com

1.3.1 Technical Customer Support

Positron is committed to providing excellent ongoing technical support to its customers. A team of specialists is always available for telephone consultations or for on-site visits to assist in the maintenance and troubleshooting of Positron equipment.

For pricing information or assistance in the planning, configuration and implementation of the installation of equipment, contact Technical Customer Service.

1.3.2 Customer Training

Full customer training courses on High Voltage Interface (HVI) are also available. For more information, contact Positron.

1.3.3 Repair Service

All warranty repairs are performed at no cost. Positron reserves the right to repair or replace any equipment that has been found to be defective.

For information about out-of-warranty repairs, contact Positron's Repair Department. Due to the varied nature of repairs, no specific turnaround can be guaranteed, but average turnaround time is 20 working days from date of receipt. In emergency situations, special arrangements can be made. All repaired items are warranted for a period of 90 days.

Before returning any items to Positron for repair, warranty repair or replacement, call the Repair department to obtain a Return Material Authorization (RMA) number. Parts returned without RMA numbers cannot be accepted. The RMA number must always be clearly marked on all boxes, crates, and shipping documents. Bulk repairs (more than five items) will require additional processing time, so please take this into consideration when requesting an RMA number.

To accelerate the repair process, whenever possible, include a report detailing the reason for return with the unit(s). Also, please include the name and phone number of a person who can be contacted should our Repair department need further information.

When packing items being returned for repair, please ensure they are properly packed to avoid further damage. Plug-in cards should never be shipped while installed in a shelf; this will cause damage that can extend the repair period.

1.4 TeleLite Warranty

Subject to the provisions of this paragraph, Positron warrants that the equipment shall perform in accordance with Positron's specifications. The warranty remains valid for one (1) year from the date of shipment. The warranty fully covers workmanship, materials and labor. Positron shall, at its sole discretion, repair or replace the problem unit.

Freight costs to ship defective equipment to Positron are borne by the Customer, with return of replaced or repaired equipment to be at Positron's expense.

1.4.1 Limitation of Liability

Subject to anything to the contrary contained herein, Positron's sole obligation and liability and the customer's sole remedy for Positron's negligence, breach of warranty, breach of contract or for any other liability in any way connected with or arising out of, the equipment or any services performed by Positron shall be as follows:

- In all situations involving performance or non-performance of the equipment or any component thereof, the customer's sole remedy shall be, at Positron's option, the repair or replacement of the equipment or said component.
- For any other claim in any other way related to the subject matter of any order under, the customer shall be entitled to recover actual and direct damages; provided that Positron's liability for damages for any cause whatsoever, and regardless of the form of the action, whether in contract or in tort (including negligence), shall be limited to the value of the order.

Positron shall not be obligated to repair or replace any item of the equipment which has been repaired by others, abused or improperly handled, improperly stored, altered or used with third party material or equipment, which material, or equipment may be defective, of poor quality or incompatible with the equipment supplied by Positron, and Positron shall not be obligated to repair or replace any component of the equipment which has not been installed according to Positron specifications.

IN NO EVENT SHALL POSITRON BE LIABLE FOR ANY INDIRECT, INCIDENTAL, SPECIAL, CONSEQUENTIAL, PUNITIVE, EXEMPLARY OR SIMILAR OR ADDITIONAL DAMAGES INCURRED OR SUFFERED INCLUDING LOSS OF PROFITS, LOSS OF REVENUES, LOSS OF DATA, LOSS OF

BUSINESS INFORMATION, LOSS OF GOODWILL, LOSS OF EXPECTED SAVINGS OR BUSINESS INTERRUPTION ARISING OUT OF OR IN CONNECTION WITH THE EQUIPMENT, A PURCHASE ORDER SUPPLIES, MAINTENANCE SERVICES OR OTHER SERVICES FURNISHED HEREUNDER, EVEN IF POSITRON HAS BEEN ADVISED OR IS AWARE OF THE POSSIBILITY OF SUCH DAMAGES.

EXCEPT AS EXPRESSLY SET FORTH IN THIS AGREEMENT, POSITRON DISCLAIMS ANY FURTHER CONDITIONS, REPRESENTATIONS OR WARRANTIES, WHETHER WRITTEN OR ORAL, EXPRESSED OR IMPLIED, INCLUDING THE CONDITIONS AND WARRANTIES OF MERCHANTABILITY, MERCHANTABILITY QUALITY, FITNESS FOR A PARTICULAR PURPOSE, TITLE, PERFORMANCE AND THOSE ARISING FROM STATUE, TO THE EXTENT PERMITTED BY LAW. POSITRON DOES NOT WARRANT THAT THE SYSTEM WILL OPERATE WITHOUT INTERRUPTION OR THAT IT WILL BE ERROR FREE.

1.4.2 Cancellation and Rescheduling Charges

Should the customer cancel, prior to shipment, any part of an order, the customer agrees to pay to Positron cancellation charges, not as a penalty, which shall total all expenses, including labor expenses, incurred by Positron prior to said cancellation. Equipment that has been specially developed for the customer's specific applications shall not be subject to cancellation. Cancellation or rescheduling is not permissible after shipment of the System.

Chapter 2

Overview

2.1 TeleLite System Introduction

TeleLite provides electrical isolation between two points on a telecom landline. Its purpose is to increase electrical isolation between the CO (Central Office) side and Station side. The increase in electrical isolation is achieved by using a fiber optic link. The Station side unit is located either inside or outside the building. The CO side must be located far enough from the Station side so that the GPR does not increase above 300 V with respect to the CO.

The TeleLite system is divided into two parts: the CO side unit and the Station side unit. Each unit is composed of one shelf. Each shelf has six slots for line cards and one slot for a power connection.

The communications link between the CO side unit and the Station side unit supports two types of fibers, single-mode or multi-mode, depending on the customer installation.

2.1.1 Introduction to the Power/Access Card model 721123

The Power/Access card can be housed in any slot in a TeleLite 2-, 3-, or 6-position shelf. This card provides:

- Electrical conversion between the station 129 Vdc or 120 Vac and the backplane -48 Vdc.
- Fusing of the power inputs
- Alarm contacts
- 50W output power at 25°C (77°F), 30W at 60°C (140°F)

2.1.2 Power Contacts

- The Power/Access card can accommodate input of either 129 Vdc or 120 Vac and provides - 48 Vdc power to the shelf. Polarity markings on the terminal block are used when providing an input of 129 Vdc. When providing an input of 120 Vac, the (N) terminal is for the neutral (white wire connection) and (L) input for the live (black wire).

2.1.3 Power Alarm 1 & 2 Contacts

The Power/Access card has power alarm pins that provide a contact closure between pins (PWR ALRM 1 and PWR ALRM 2) when the Power/Access card is no longer providing -48V to the shelf. This mechanism can be used to provision an audio or visual indication of a fault condition. Two LEDs (see section 2.1.6 on page 15 below) are also provided for local indication of power.

2.1.4 Local Alarm 1 & 2 Contacts

If any circuit card on the Station side shelf experiences a fault condition, the local alarm relay contact (normally open) between pins (LCL ALRM 1 and LCL ALRM 2) will close, allowing current to flow through an externally provided circuit. This mechanism can be used to provision an audio or visual indication of a fault condition.

2.1.5 Remote Alarm 1 & 2 Contacts

If any circuit on the CO side shelf experiences a fault condition, this indication is communicated over the fiber to the Station side shelf Power/Access card. The remote alarm contact between pins (RMT ALRM 1 and RMT ALRM 2) will close, allowing current to flow through an externally provided circuit. This mechanism can be used to provision an audio or visual indication of a fault condition.

NOTE

The local and remote alarm pins on the Power/Access card on the CO side (if provisioned) are not used since the equipment is located at the mid span, where typically there is no equipment to monitor alarms.

2.1.6 LED Indicators

Two LED indicators, In and Out are provided.

- The In LED glows green when the input power is correct, and will be off if input power is not correct.
- The Out LED glows amber when the output power of the card is at -48 Vdc and will be off if output power is not correct.

Figure 1: Power/Access Card Terminal Block (CO and Station side)

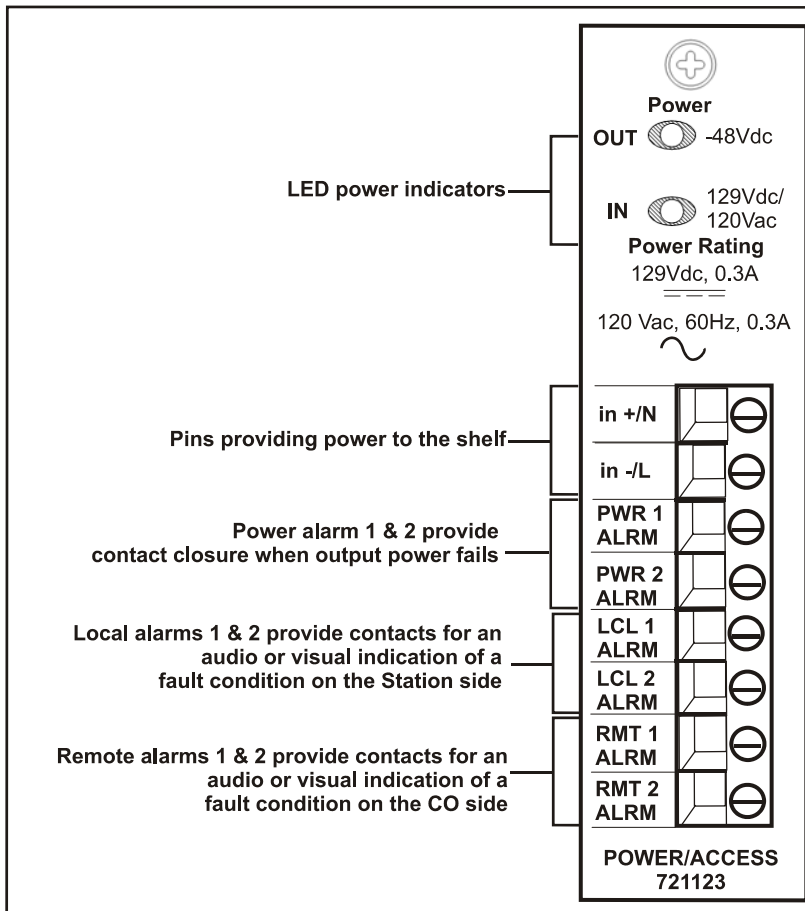

Table 2: Access Card Pinouts

Terminal Block	Station Side Function	CO Side Function
in +/N	Neutral input for 120 Vac or Positive input for 129 Vdc	Neutral input for 120 Vac or Positive input for 129 Vdc
in -/L	Live input for 120 Vac or Negative input for 129 Vdc	Live input for 120 Vac or Negative input for 129 Vdc
PWR ALRM	Power Alarm 2 pins provide contact closure when output power is no longer - 48 Vdc	Provides contact closure when output power is no longer - 48 Vdc
LCL ALRM	Local Alarm 2 pins provide normally open dry relay contact closure for an audio or visual indication of a fault condition on the Station side	Not used
RMT ALRM	Remote Alarm 2 pins provide normally open dry relay contact closure for an audio or visual indication of a fault condition on the CO side	Not used

NOTE

The TeleLite Power/Access card contains two non-replaceable fuses. In the event either fuse blows, the card must be returned to Positron for service.

NOTE

The 129 Vdc power to the Power/Access card is not polarity sensitive. Card will operate normally if polarity is reversed.

CAUTION

Input power must be removed when the card is being inserted or removed from the shelf. Lethal voltages are present when input power is present.

2.1.7 Power/Access Card Specifications

Table 3: Environmental Specifications

Parameter	Specification
Operating Temperature	-40°F to 140°F (-40°C to 60°C)
Storage Temperature	-40°F to 185°F (-40°C to 85°C)
Humidity (non-condensing)	15% to 90%
Altitude	-200 ft to 13,000 ft (-61 m to 3965 m)

Table 4: Electrical Specifications

Parameter	Specification
Shelf Voltage Input	129 Vdc (112 Vdc to 145 Vdc) 120 Vac (114 Vac to 125 Vac)
Maximum Output Power	50W up to 40°C (104°F) then derates to 30W at 60°C (140°F)
Maximum Input Current	0.5A at 50W output 0.3A at 30W output
Load Regulation	better than 1.5%
Line Regulation	better than 0.1%
Inrush Current	33A peak for 5 usec
Output Ripple	less than 100mVpp
Switching Noise	less than 100mVpp
Power Dissipation	30% of power to load
Shelf Maximum Current	1 A
Alarm Contact Rating	62.5VA, 125Vac, 2A

NOTE

Unit shuts down if internal temperature rises above 100°C (212°F).

Chapter 3

Installation

3.1 Installing a Power/Access Card in a Shelf

After a shelf has been properly installed and the ground connection completed, the TeleLite Power/Access card can be installed.

Follow the ESD precautions shown in Figure 2.

Figure 2: ESD Precautions

 <p>ATTENTION ELECTROSTATIC SENSITIVE DEVICES HANDLE ONLY AT STATIC SAFE WORKSTATION</p>	<p>ESD Precaution INCORRECT HANDLING MAY VOID WARRANTY</p> <p>These procedures must be followed when handling an electrostatic sensitive device.</p> <ul style="list-style-type: none">• A grounded wrist strap must be worn at all times during installation.• When unpacking, place the antistatic bag containing the device on an electrostatic discharge (ESD) safe surface. An ESD safe surface is a conductive surface connected directly to an earth ground.• When moving, carry the device in an ESD safe container or the antistatic bag, provided with the device.
---	--

► To Install a Power/Access Card in a Shelf

1. Remove the card from its protective packaging.
2. Make sure the card is right-side up, align the card with the appropriate slot of the shelf and slide it in, as shown below. In this figure the card is depicted in the first slot, but the Power/Access card can be installed in any slot. In all our pre-configured HVI assemblies (not shown here), the Power/Access card is installed in the seventh slot to facilitate the power connections.
3. Hand-tighten the top and bottom screws, to secure the card in place.
4. Connect the power and alarm connections on the terminal block on the faceplate.
 - When providing an input of 129 Vdc, observe the polarity markings on the terminal block.
 - When providing an input of 120 Vac, the (N) terminal is for the neutral (white wire connection) and (L) input for the live (black wire).

Figure 3: Installing an interface card in a shelf

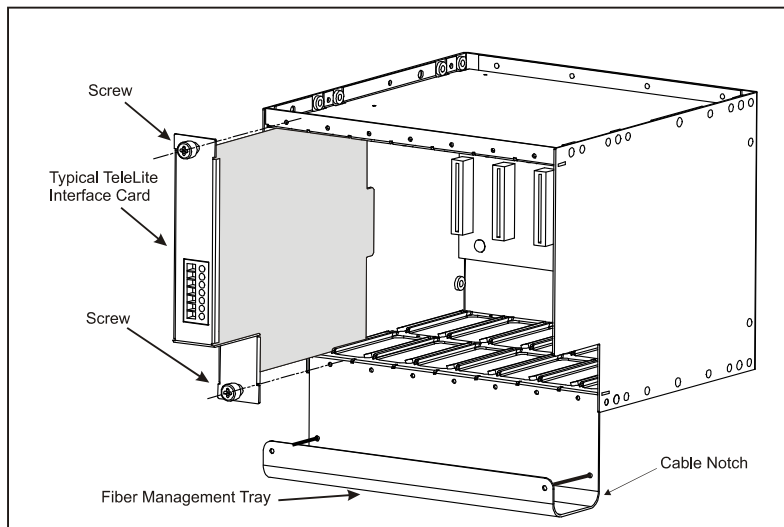

3.1.1 Earthing Connector

CAUTION

To ensure safety of personnel, Positron recommends following these guidelines:

- The return of the DC supply must be grounded at the source.
- The 120 Vac supply must be grounded.
- This equipment must be permanently connected to earth.
- The field wiring should include a readily-accessible disconnect device. The disconnect device shall disconnect both poles, positive (or neutral) and negative (or live).
- This equipment is connected directly to the DC supply system earthing electrode conductor or to a bonding jumper from an earthing terminal bar or bus to which the DC supply system earthing electrode is connected.
- This equipment must be located in the same immediate area (such as adjacent cabinets) as any other equipment that has a connection between the earthed conductor of the same DC supply circuit and the earthing conductor, and also the point of earthing of the DC system. The DC system shall not be earthed elsewhere.
- The DC supply source must be located within the same premises as this equipment.
- There shall be no switching or disconnecting devices in the earthed circuit conductor between the DC source and the point of connection of the earthing electrode conductor.

3.1.2 Troubleshooting

Before calling customer service, make sure that:

- The card is properly inserted
- 129 Vdc or 120 Vac is available on the terminal block of the Power/Access card

Appendix A

Acronyms

A 1 Acronyms

AC	Alternating Current
ALRM	Alarm
CO	Central Office
DC	Direct Current
ESD	Electro-Static Discharge
GPR	Ground Potential Rise
HVI	High Voltage Interface
LCL	Local
LED	Light-emitting Diode
PWR	Power
RMA	Return Material Authorization
RMT	Remote
RTN	Return