

Standalone Power Supply Unit 130 V dc to -24 V dc, 7715-2

Description and Installation



DOCUMENT CONTROL INFORMATION

Document Part Number: 7715-24-02, Rev 4
Document Issue Number: 4
Publication Date: January 07, 2003
Document ID: (o02j7000.fm)

CONFIDENTIALITY NOTICE

The information contained in this document is the property of Positron Inc. Except as specifically authorized in writing by Positron Inc., the holder of this document: 1) shall keep all information contained herein confidential and shall protect same in whole or in part from the disclosure and dissemination to all third parties, and 2) shall use same for operating and maintenance purposes only.

DISCLAIMER NOTICE

Although Positron Inc. has made every effort to ensure the accuracy of the information contained herein, this document is subject to change without notice.

TECHNICAL CUSTOMER SUPPORT

Should a problem arise, contact your customer support department. If the problem cannot be resolved by your support department or if you have any questions, contact Positron's Technical Customer Support department at 1-888-577-5254.

© 2003 Positron Inc.

Teleline Isolator is a registered trademark of Positron Inc.

Product names, other than Positron's, mentioned herein may be trademarks and/or registered trademarks of their respective companies.

- 1. The Standalone Power Supply Unit 1
- 2. Hardware Description 4
- 3. Technical Specifications 6
- 4. Installation 7
 - 4.1 Mechanical Installation 9
 - 4.1.1 Wall Mount 10
 - 4.1.2 Teleline Shelf Mount 10
 - 4.2 Electrical Installation 11
- 5. Service and Support 13

1. The Standalone Power Supply Unit

The Standalone Power Supply Unit, model 7715-2 converts floating 130 V dc from a station battery to -24 V dc referenced to station ground. This large capacity standalone power supply may be used to power a fully loaded Three, Five or Eight-card Shelf. For a view of the Standalone Power Supply Unit, refer to Figure 1.

The installation kit consists of the Standalone Power Supply Unit, in a durable, metal enclosure. The kit contains a Description and Installation document, mounting platform, connecting cables, and mounting hardware.

Attention

This unit cannot be used in conjunction with any other -24 V dc power supply of the Teleline product line, whether of the standalone or plug-in variety. For a complete list of incompatible equipment, refer to Table 3.

Figure 1 Model 7715-2

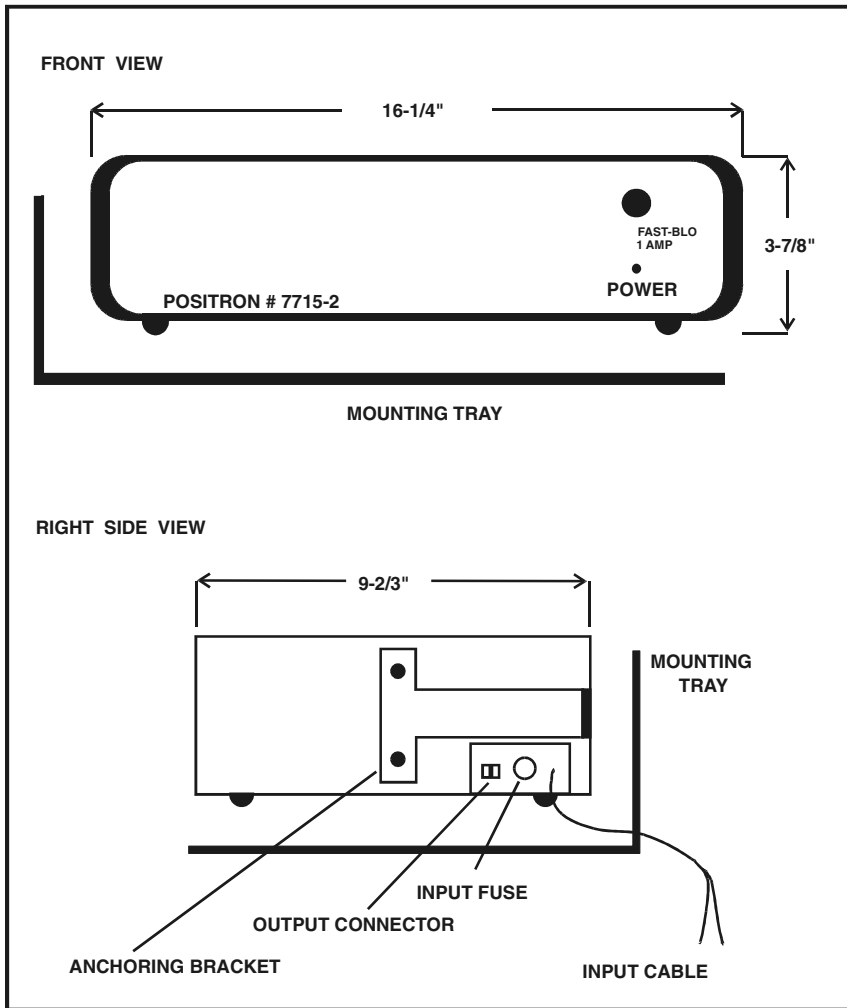

Its features include the following:

- The unit may be used with any old and new generation Three, Five or Eight-card Teleline Shelf.
- The unit supplies continuous -24 V dc at up to 2 A from a 130 V dc floating station battery, without compromising its floating nature.
- The supply uses high-reliability, solid state switching technology to perform the DC to DC conversion.
- The supply's input is protected against overvoltage transients.
- Two one-amp input fuses protect the power supply against ground faults, and the station battery against a malfunction of the supply. The fuse on the line wire is also accessible from the front panel.
- The unit is equipped with a current limiting circuit at its input to prevent an excessive current surge upon connection of the station battery.
- The unit is equipped with a current limiter at the output for short circuit protection.
- A green "Power Output" LED located on front panel indicates the presence of -24 V dc output.

2. Hardware Description

For the unit's block diagram, refer to Figure 2.

Figure 2 Block Diagram

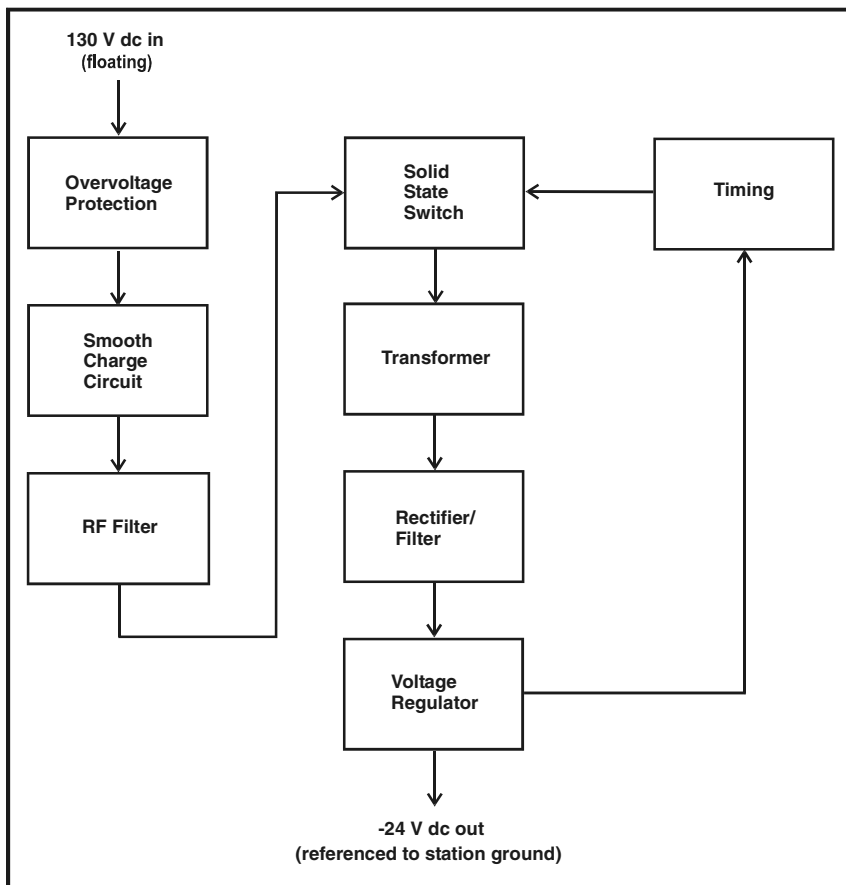

The following is a description of the elements of the Standalone Power Supply Unit block diagram.

Overvoltage Protection

The Overvoltage Protection is supplied by metal oxide varistors (MOVs) in metallic and longitudinal configuration that will blow the input fuses in case of sustained overvoltage at the input.

Smooth Charge Circuit

The Smooth Charge Circuit is a current limiter that limits the charging current on initial connection to the batteries.

RF Filter

The RF Filter prevents switching noise from the power supply from being introduced onto the power leads.

Solid State Switch

The Solid State Switch is the switching circuit of the switch mode power supply.

Transformer

The Transformer provides 1500 V isolation while stepping down the voltage for the regulator.

Rectifier/Filter

The Rectifier/Filter circuit rectifies the switching current coming out of the transformer and charges the capacitor of the filter to produce a DC voltage.

Voltage Regulator

The Voltage Regulator steps down the voltage out of the power supply to a precise and steady -24 V dc.

Timing

The Timing circuit is a feedback circuit that monitors the output voltage and increases or decreases the pulse width of the switch to maintain a controlled voltage before the regulator.

3. Technical Specifications

For a listing of the unit's electrical specifications, refer to Table 1. For a listing of the unit's physical specifications, refer to Table 2.

Table 1 Electrical Specifications (measured at 77°F or 25°C)

Parameter	Specifications
Input station voltage	105 to 150 V dc
Input power at full load	65 W
Nominal output voltage	-24 V dc
Maximum output current	2.0 A
Maximum output power	48 W
Output ripple voltage	100 mV _{pp}
Regulation, line	<1.0%
Regulation, load	<5.0%
Input/output isolation	1500V @ 60 Hz for 1 minute

Table 2 Physical Specifications

Parameter	Specifications
Operating temperature range	+32°F to +122°F (0°C to + 50°C)
Height	3.9" (9.9 cm)
Width	16.3" (41.4 cm)
Depth	9.7" (24.6 cm)
Weight	6.8 lbs (3.1 kg)

4. Installation

This installation procedure assumes that the Three, Five or Eight-card Shelf being used has already been mounted as per its installation instructions. For further information, refer to the Description and Installation documentation for the Three-card Shelf, model 751127, part number 924-010186-001, Five-card Shelf, model 751112/1, part number 924-010199-001, or Eight-card Shelf, model 751109/13, part number 924-010040-001.

Caution

- Stand on a thick rubber mat and wear rubber gloves during the installation procedure. It is preferable to perform these procedures on a clear dry day when a Ground Potential Rise (GPR) or transients are less likely to occur.
- This unit utilizes CMOS circuitry that can be damaged by static electricity. The unit is not to be opened.

1. Verify that you are not using any equipment which is incompatible with the Standalone Power Supply Unit. Do not use power supply 7715-2 with any other plug-in or standalone -24 V dc power supply. For a listing of incompatible equipment, refer to Table 3.

Table 3 Incompatible Equipment

Do Not Use Power Supply 7715-2 with the Following Equipment	
A shelf containing one or more -24 V dc plug-in power supply cards (the -24 V dc plug-in card must be permanently removed from the shelf if a standalone -24 V dc supply is used)	751313 751316 751324
A shelf powered by any other -24 V dc standalone power supply	7715-2 7715-3 7856-3

2. Verify that you have the following customer provided tools and hardware which are required to install the unit.
 - Center punch
 - Electric drill with a 5/32" diameter bit
 - 7/16" hex wrench
 - Phillips screwdriver
 - Cable clamps and mounting hardware for routing cables exterior to the shelf (quantity determined by the cable lengths involved).
3. Unpack the Standalone Power Supply Unit and its installation hardware from its protective box.
4. Check the contents of your Standalone Power Supply Unit kit. For a listing of the items included in the kit, refer to Table 4.

Table 4 Model 7715-2 Kit Contents

Items Included	Qty	Part Number
Standalone Power Supply Unit	1	244-040024-401
Description and Installation document	1	7715-24-02
Mounting platform	1	7856-02-09
6.5' Power supply input cable (pre-wired to supply)	1	207-010091-401
6.5' Power supply output cable	1	207-010087-401
Anchoring brackets	2	7856-02-07
Hex screws with washers (#14A, 1" long)	3	724-990000-011
Mounting bolts (1/2" long)	2	724-020001-029
Washers #10 flat	2	738-990110-005
Lock washers #10	2	738-990010-005

5. Confirm that the unit is a Standalone Power Supply Unit by identifying the model number on its faceplate.

4.1 Mechanical Installation

The Power Supply Unit can be installed on a self-supporting wall-mounted tray, or directly on the Teleline shelf. For an illustration of its installation, refer to Figure 3.

Figure 3 Model 7715-2 Installation

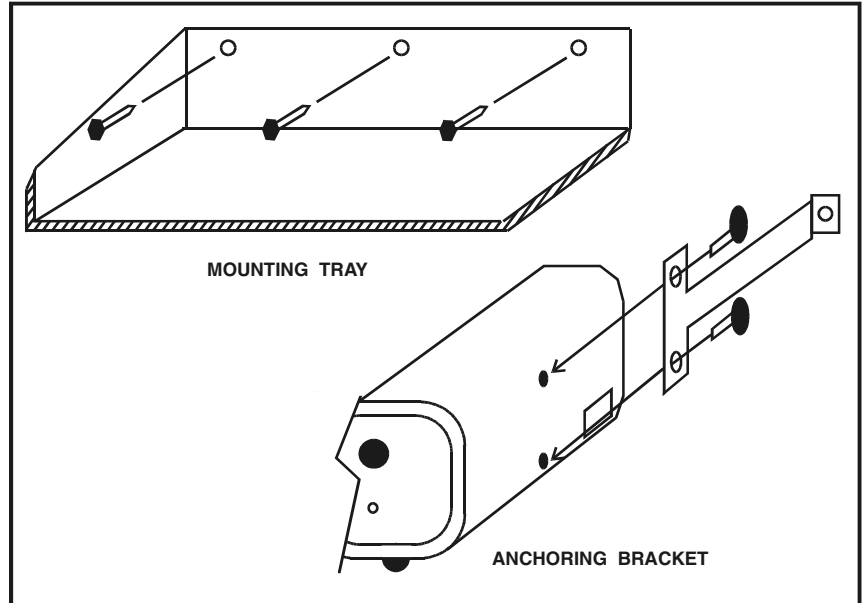

4.1.1 Wall Mount

1. Using the mounting tray as a template, position it against the desired location (above or beside the shelf) and drill three, 5/32" diameter holes into the 1" plywood surface.
2. Fasten the tray to the wall using the three, #14A screws and washers provided.
3. Align the holes on the left side of the power supply enclosure with those on the left side of the mounting tray. Use the two, 1/2" bolts and washers to attach the two parts together.

4.1.2 Teleline Shelf Mount

1. Attach an anchoring bracket to each side of the power supply enclosure.
2. Position the power supply on the Teleline shelf, against the wall. Anchor the unit in place by fastening the brackets to the wall.

4.2 Electrical Installation

Caution

The station and Central Office (CO) cables should be kept at least six inches apart upon wiring in order to prevent an electric arc between the two in the event of damage to, or degradation of, their insulation.

1. Route the station battery cables to the power supply input cable. The table below lists the power supply input connections. For a listing of the Power Supply Unit's input connections, refer to Table 5.

Table 5 Power Supply Unit Input Connections

Station	Power Supply Input
130 V dc battery, negative pole	Red
130 V dc battery, positive pole	Black
Station ground	White

2. Connect the power supply output to the shelf. For a Five or Eight-card Shelf, this may be accomplished via the Station side cable or by using a separate power cable. For a Three-card Shelf, the only entry is through the Station side cable. For a listing of the Power Supply Unit's output connections, refer to Table 6.

Table 6 Power Supply Unit Output Connections

Power Supply Output	Shelf Terminal Designation
Black	GND
White	-24 V

3. Ensure that there are no excess wires dangling into the isolation gap between the Station and CO side circuits. Then close and secure the shelf cover with the captive screws.
4. Verify that you obtain -24 V inside the shelf.

Note

Blown fuses are the only circuit components to be replaced by customer maintenance personnel. Contact Positron should any other maintenance be required.

5. Service and Support

Technical Customer Support

Positron is committed to providing excellent ongoing technical support to its customers. A team of specialists is always available at our Technical Support Center in Montreal for either telephone consultations or on-site visits, to assist Field Technical personnel in the maintenance and troubleshooting of Positron equipment. During normal business hours, (8:30 a.m to 5:00 p.m. EST), any one of our Technical Customer Support (TCS) staff may be reached by dialing 1-888-577-5254 from anywhere in the continental United States or from Canada. Customers outside North America should dial 1-514-345-2200. Staff may also be contacted via fax at 514-345-2271 or e-mail at powerdivision@positron.qc.ca.

Positron TCS staff are available to provide technical assistance and/or to supervise the installation of Positron equipment. Assistance in the planning, configuration, and implementation of the installation will be provided as requested. Arrangements and pricing information regarding field assistance may be obtained by contacting the Technical Customer Support department. Please contact Positron for scheduling at least four weeks prior to the actual requested visit date.

Customer Training

Positron offers full customer training courses, as requested. Seminars are also available on High Voltage Interface (HVI). For more information, contact a customer representative by dialing 1-888-577-5254 or use our e-mail address, powerdivision@positron.qc.ca.

Warranty

Positron warrants that all equipment shall perform in accordance with Positron's specifications. The warranty remains valid for five (5) years from the date of shipment. The warranty will be honored provided that the equipment has not been abused and provided that the equipment has been installed and used in accordance with Positron's installation instructions and specifications. The warranty fully covers workmanship, materials and labor.

This warranty is in lieu of all other warranties, whether expressed or implied, including warranties of merchantability and fitness for a particular purpose. Positron guarantees that all equipment shall perform in accordance with Positron's specifications. Positron disclaims any warranty that Positron

equipment will meet customer requirements beyond the product specification. Positron disclaims any warranty that operations will be uninterrupted or error free.

Repair Service

Positron Inc. offers repair services by which customers can count on timely and quality repairs, regardless of customer location.

All warranty repairs are performed at no cost. Positron reserves the right to repair or replace any equipment which has been found to be defective.

For information about out-of-warranty repairs, contact Positron's Repair department at 1-800-661-4911 (from anywhere in the continental United States or from Canada) or dial 514-345-2228. Due to the varied nature of repairs, no one time frame for turnaround can be guaranteed. However, average turnaround time is two weeks from date of receipt. In emergency situations, special arrangements can be made by contacting our Repair department. All repaired items are warranted for a period of 90 days. Bulk repairs (more than five items) will require additional processing time, therefore, please take this into consideration when requesting a Return Material Authorization (RMA) number.

Before returning any items to Positron for repair, warranty repair or replacement, call the Repair department to obtain an RMA number. Parts returned without RMA numbers cannot be accepted. The RMA number must always be clearly marked on all boxes and crates and on all shipping documents.

Items under warranty are to be shipped prepaid to Positron and will be returned prepaid to the customer. Items that are not under warranty are to be shipped prepaid to Positron and will be returned prepaid with freight charges included on the invoice. Positron cannot accept items shipped collect. A purchase order number is required for all repairs.

To accelerate the repair process, whenever possible, customers should include a report detailing the reason for return with the unit(s) being returned. Also, please include the name and phone number of a person who can be contacted should our Repair department need further information.

When packing items being returned for repair, please ensure that the item(s) is properly packed to avoid further damage. Teleline Isolator cards should never be shipped while installed in a shelf; this will cause damage and will almost invariably extend the repair period.

Ordering Information

Positron's Teleline equipment can be ordered by telephone, facsimile, or by mail. All orders should be directed to the Positron Inside Sales department. Ordering by telephone, or facsimile will eliminate any delays arising from postal services. However, a hard copy purchase order is required as a confirmation. In addition to the model numbers of the items being ordered, the following information is required:

- Company name, contact name and telephone number
- Purchase order number
- "Ship To" address
- "Bill To" address
- Date required on site

All orders must be followed by a confirming order. Equipment will not be shipped until such confirmation is received.

For a list of our contact information, refer to Table 7.

Table 7 Positron Contact Information

Address	Positron Inc.
	5101 Buchan St.
	Montreal, Quebec, Canada
	H4P 2R9
Main telephone number	514-345-2200
Customer Service department telephone number	514-345-2200, 1-888-577-5254
General e-mail address	powerdivision@positron.qc.ca
Customer Service department fax number	514-345-2271
TCS department toll-free number	1-888-577-5254
TCS department fax number	514-345-2271
TCS department e-mail address	scarbonaro@positron.qc.ca
Repair department telephone numbers	514-345-2228 or 1-800-661-4911
Customer representative e-mail address	customerservicepower@positron.qc.ca

